



RDF300, RDF300.02, RDF340
RDF600



RDF400.01
RDF600T

Semi flush-mount room thermostats

RDF300...
RDF340
RDF400...
RDF600...

for 2-pipe, 2-pipe with el. heater and 4-pipe fan coil units
for use with compressors in DX type equipment

- **RDF300 / RDF400 / RDF600/RDF600T:**
AC 230 V operating voltage, on/off or 3-position control outputs
- **RDF340...:**AC 24 V, operating voltage, DC 0...10 V control outputs
- Output for 3-speed or 1-speed fan
- 2 multifunctional inputs for keycard contact, external sensor, etc.
- Operating modes: Comfort, Economy and Protection
- Automatic or manual fan speed control
- Automatic or manual heating/cooling changeover
- Adjustable commissioning and control parameters
- Minimum and maximum setpoint limitation

Additional features

- Backlit LCD (RDF300.02, RDF400.01, RDF600, RDF600T)
- Infrared remote control receiver (RDF400.01, RDF600T)
- Auto Timer mode with 8 programmable timers (RDF400.01, RDF600T)

Type of mounting / suitable conduit boxes

- RDF600... for round CEE box, with min 60 mm diameter, min 40 mm depth
- RDF3... / RDF400... for recessed rectangular box with 60.3 mm fixing centers

Use

Applications

To control the room temperature in individual rooms and zones that are:

- Heated or cooled with 2-pipe fan coil units
- Heated or cooled with 2-pipe fan coil units with electric heater
- Heated and cooled with 4-pipe fan coil units
- Heated or cooled with compressor in DX type equipment
- Heated or cooled with compressor in DX type equipment with electric heater
- Heated and cooled with compressor in DX type equipment

The RDF300... / RDF400... / RDF600... control:

- One 1- or 3-speed fan
- One or 2 on/off valve actuators
- One on/off valve actuator and one 1-stage electric heater
- One 3-position valve actuator
- One 1-stage compressor in DX type equipment or one 1-stage compressor with electric heater

The RDF340... controls:

- One 1- or 3-speed fan
- One or 2 DC 0...10 V valve actuators
- One DC 0...10 V valve actuator and one modulating electric heater (DC 0...10 V)

Used in systems with:







- Heating or cooling mode
- Automatic heating/cooling changeover
- Manual heating/cooling changeover
- Heating and cooling mode (e.g. 4-pipe system)

Functions

- Maintain room temperature via built-in temperature sensor or external room temperature / return air temperature sensor
- Automatic or manual changeover between heating and cooling mode
- Select applications via DIP switches
- Select operating mode via the operating mode button on the thermostat
- 1- or 3-speed fan control (automatic or manual)
- Display current room temperature or setpoint in °C and/or °F
- Minimum and maximum setpoint limitation
- Button lock (automatic and manual)
- 2 multifunctional inputs, freely selectable for:
 - Operating mode switchover contact (key card)
 - Automatic heating/cooling changeover sensor
 - External room temperature or return air temperature sensor
 - Dewpoint sensor
 - Electric heater enable
 - Alarm input
- Advanced fan control function, i.e. fan kick, fan start, selectable fan operation (enable, disable or depending on heating or cooling mode)
- Purge function together with 2-port valve in a 2-pipe changeover system
- Reminder to clean filters
- Floor heating temperature limit
- Reload factory settings for commissioning and control parameters
- 7-day time program: 8 programmable timers to switch over between Comfort and Economy mode (RDF400.01 / RDF600T)
- Backlit LCD (RDF300.02 / RDF400.01 / RDF600 / RDF600T)
- Optional infrared remote control (RDF400.01 / RDF600T)

Applications

The thermostat supports the following applications, which can be configured by DIP switch on the inner side of the thermostat's front. Depending on the type, on/off or modulating control outputs are available.

	Application and control outputs	DIP-switch	Product no.
2-pipe fan coil unit heating or cooling	2-pipe / 1-stage compressor on/off		RDF300, RDF600 RDF400, RDF600T
	2-pipe modulating, DC 0...10 V		RDF340
	2-pipe modulating, 3-position		RDF300, RDF600 RDF400, RDF600T
2-pipe fan coil unit with el. heater heating or cooling, with auxiliary heater	2-pipe / 1-stage compressor with electric heater, on/off		RDF300, RDF600 RDF400, RDF600T
	2-pipe with electric heater modulating, DC 0...10 V Note: modulating el heater		RDF340
4-pipe fan coil unit heating and cooling	4-pipe / compressor for H+C on/off		RDF300, RDF600 RDF400, RDF600T
	4-pipe modulating, DC 0...10 V		RDF340

Type summary

Product number	Stock number	Features	Control outputs			Time program	Backlit LCD	Infrared receiver ¹⁾	Suitable conduit box ²⁾
			Operating Voltage	on/off	3pt				
RDF300	RDF300	AC 230V	✓	✓				rectangular	
RDF300.02	RDF300.02	AC 230V	✓	✓			✓	rectangular	
RDF400.01	RDF400.01	AC 230V	✓	✓		✓	✓	rectangular	
RDF340	RDF340	AC 24V			✓			rectangular	
RDF600	S55770-T291	AC 230V	✓	✓			✓	round	
RDF600T	S55770-T292	AC 230V	✓	✓		✓	✓	round	

1) Infrared remote control is to be ordered as separate item



















2) Rectangular conduit box e.g. ARG71.

Round conduit box min 60 mm diameter and min 40 mm depth

Ordering



- When ordering, indicate both product number / SSN number and name:
E.g. **RDF600 / S55770-T291 room thermostat**
- Order the **IRA211 (S55770-T166)** infrared remote control separately (for RDF400../RDF600...).
- Order valve actuators separately.

Equipment combinations

	Designation	Product no.	Data Sheet
	Infrared remote control 	IRA211	3060
	Cable temperature sensor 	QAH11.1	1840
	Room temperature sensor 	QAA32	1747
	Condensation detector / Supply unit 	QXA2000 / QXA2001 / AQX2000	1542
<i>On / off actuators</i>	Electromotoric on / off valve and actuator (only available in AP, UAE, SA and IN) 	MVI.../MXI...	4867
	Electromotoric on / off actuator 	SFA21...	4863
	Thermal actuator (for radiator valve) 	STA23... STA21... *)	4884 4893 *)
	Thermal actuator (for small valves 2.5 mm) 	STP23... STP21... *)	4884 4893 *)
	Zone valve actuators (only available in AP, UAE, SA and IN) 	SUA...	4832
<i>3-position actuators</i>	Electrical actuator, 3-position (for radiator valve) 	SSA31...	4893
	Electrical actuator, 3-position (for small valve 2,5 mm) 	SSP31...	4864
	Electrical actuator, 3-position (for small valve 5,5 mm) 	SSB31...	4891
	Electromotoric actuator, 3-position (for valves 5.5 mm) 	SQS35...	4573
<i>DC 0...10 V actuators</i>	Electrical actuator, DC 0...10V (for radiator valve) 	SSA61...	4893
	Electrical actuator, DC 0...10V (for small valve 2,5 mm) 	SSP61...	4864
	Electrical actuator, DC 0...10V (for small valves 5.5 mm) 	SSB61...	4891
	Electromotoric actuator, DC 0...10V (for valves 5.5 mm) 	SQS65...	4573
	Thermal actuator, DC 0...10V (for small valves and radiator valves) 	STS61	4880

*) Not available any more

Accessories

Designation	Product no.	Data Sheet
Changeover mounting kit (50 pcs/package) 	ARG86.3	N3009
Plastic mounting bracket for semi-flush-mount thermostats RDF3.. RDF400... for increasing the headroom in the conduit box by 10mm 	ARG70.3	N3009
Conduit box for semi-flush mounted thermostat RDF3.. RDF400... 	ARG71 / S55770-T137	N3009

The thermostat consists of 2 parts:

- Front panel accommodating the electronics, operating elements and built-in room temperature sensor.
- Mounting base with the power electronics.

The rear of the mounting base contains the screw terminals.

Slide the front panel in the mounting base and snap on.

Operation and settings

RDF300.../RDF340...
RDF600



1. Operating mode selector / Protection
2. Change fan operation
3. Adjust setpoint and control parameters

RDF400...
RDF600T

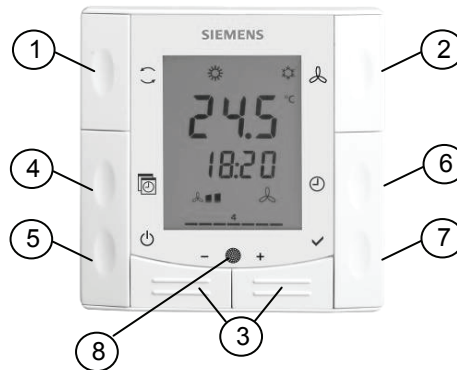

1. Change operating mode selector
2. Change fan operation
3. Adjust setpoint, control parameters and time of day
4. Auto Timer program
5. Protection
6. Set time of day and weekday
7. Confirm
8. Infrared receiver

Display

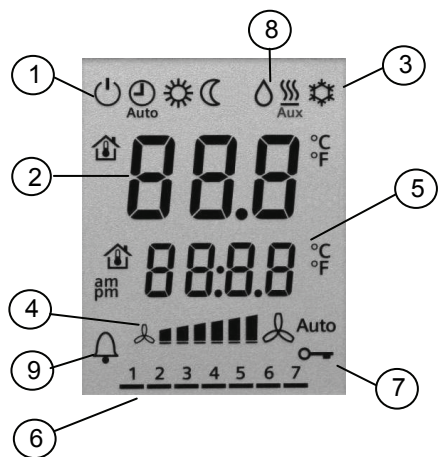

1. Operating mode
 - ⏻ Protection
 - 🕒 Auto Timer mode *
 - ☀️ Comfort
 - 🌙 Economy

2. Display room temperature, setpoints and control parameters.
 - 🏠 Symbol used to display the current room temperature
 3. Heating/cooling mode
 - ⚙️ Cooling mode
 - 🔥 Heating mode,
 - 🔥 Aux Electric heater active
 4. Fan mode
 - 🌀 Auto Auto fan active
 - 🌀 Fan speed low, medium, high
 5. Additional user information (RDF3xx) or current time of day (RDF400 / RDF600T)
 6. Weekday 1..7 (1 = Monday/7 = Sunday)*
 7. Button lock active
 8. Condensation in room (dewpoint sensor active)
 9. Indicate fault or reminder
- * only on RDF400... / RDF600T

Mounting and installation

Mount the room thermostat on the conduit box. Do not mount on a wall in niches or bookshelves, behind curtains, above or near heat sources, or exposed to direct solar radiation. Mount about 1.5 m above the floor.

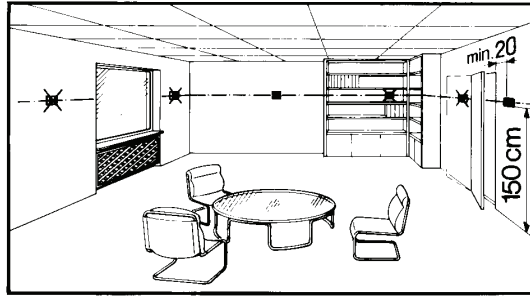

Mounting / dismounting



- Devices must be mounted on clean, dry indoor place without direct airflow from a heating / cooling device, and not be exposed to dripping or splashing
- RDF3... / RDF400... : In case of limited space in the conduit box use the mounting bracket ARG70.3 to increase the headroom by 10mm
- Before removing the front cover, disconnect the power supply.

Wiring



See the mounting instructions enclosed with the thermostat:

M3076... for RDF3..., RDF4... ; M3063 for RDF600... .

- Comply with local regulations to wire, fuse and earth the thermostat.
- Properly size the cables to the thermostat, fan and valve actuators for AC 230 V mains voltage.
- Use only valve actuators rated for AC 230 V on RDF300... / RDF400... / RDF600..
- The AC 230 V mains supply line must have an external fuse or circuit breaker with a rated current of no more than 10 A.
- Isolate the cables of SELV inputs X1-M/X2-M if the conduit box carries AC 230 V mains voltage.
- Inputs X1-M or X2-M of different units (e.g. summer/winter switch) may be connected in parallel with an external switch. Consider overall maximum contact sensing current for switch rating.
- No metal conduits
- No cables provided with a metal sheath
- Disconnect from supply before opening the cover

Commissioning

Set the thermostat application via the DIP switches before snapping the front panel on the mounting base.

After power is applied, the thermostat carries out a reset during which all LCD segments flash indicating that the reset was correct. After the reset, which takes about 3 seconds, the thermostat is ready for commissioning by qualified HVAC staff.

The control parameters of the thermostat can be set to ensure optimum performance of the entire system (see basic documentation P3076).

Note After powerfail the thermostat restarts in the same mode as before.

Control sequence

- The control sequence may need to be set via parameter P01 depending on the application. The factory setting for the 2-pipe application is “Cooling only”; and “Heating and Cooling” for the 4-pipe application.

Compressor-based application

- When the thermostat is used with a compressor, the minimum output on-time (parameter P48) and off-time (parameter P49) for Y11/Y21 must be adjusted to avoid damaging the compressor and shortening its life.

Calibrate sensor

- Recalibrate the temperature sensor if the room temperature displayed on the thermostat does not match the room temperature measured (after min. 1 hour of operation). To do this, change parameter P05.

Setpoint and range limitation

- We recommend to review the setpoints and setpoint ranges (parameters P08...P12) and change them as needed to achieve maximum comfort and save energy.

Disposal



The device is classified as waste electronic equipment in terms of the European Directive 2002/96/EC (WEEE) and should not be disposed of as unsorted municipal waste. The relevant national legal rules are to be adhered to. Regarding disposal, use the systems setup for collecting electronic waste. Observe all local and applicable laws.

Technical data

Power supply







Rated voltage	RDF300... /400... / 600... RDF340...	AC 230 V SELV AC 24 ±20 %
Frequency		50/60 Hz
Power consumption	RDF300... / RDF400.. RDF340... RDF600...	Max. 8 VA Max. 3.5 VA / 0.8 W

Outputs

Fan control Q1, Q2, Q3-N		AC 230 V
Rating		Min. 5 mA, Max. 5(2) A
Control output Y11-N/Y21-N (N.O.)		AC 230 V
Rating		Min. 5 mA, Max. 5(2) A
Control output Y10-G0/Y20-G0		SELV DC 0...10 V
Resolution		39 mV
Current		Max. ±1 mA
Max. total load current through terminal "L" (Qx + Yxx)		Max. 7 A

Inputs

Multifunctional input X1-M/X2-M		
Temperature sensor input:		
Type		QAH11.1 (NTC)
Temperature range		0...49 °C
Cable length		Max. 80 m
Digital input:		
Operating action		Selectable (N.O./N.C.)
Contact sensing		SELV DC 0...5 V/max 5 mA
Parallel connection of several thermostats for one switch		Max. 20 thermostats per switch
Insulation against mains voltage (SELV)		4 kV, reinforced insulation
Function input:		Selectable
External temperature sensor, heating/cooling changeover sensor, operating mode switchover contact, dewpoint monitor contact, enable electric heater contact, alarm contact		X1: P38 X2: P40

Operational data	Switching differential, adjustable		
	Heating mode	(P30)	2 K (0.5...6K)
	Cooling mode	(P31)	1 K (0.5...6K)
	Setpoint setting and range		
	 Comfort	(P08)	21°C (5...40 °C)
	 Economy	(P11-P12)	15°C/30°C (OFF, 5...40 °C)
	 Protection	(P65-P66)	8°C/OFF (OFF, 5...40 °C)
	Multifunctional input X1/X2		Selectable 0...6
	Input X1		3: (P38) operating mode switchover
	Input X2		2: (P40) heating/cooling changeover sensor
Environmental conditions	Built-in room temperature sensor		
	Measuring range		0...49 °C
	Accuracy at 25 °C		< ± 0.5 K
	Temperature calibration range		± 3.0 K
	Settings and display resolution		
	Setpoints		0.5 °C
	Current temperature value displayed		0.5 °C
	Operation		As per IEC 721-3-3
	Climatic conditions		Class 3K5
	Temperature		0...50 °C
Humidity		<95% r.h.	
Standards and directives	Transport		As per IEC 721-3-2
	Climatic conditions		Class 2K3
	Temperature		-25...60 °C
	Humidity		<95% r.h.
	Mechanical conditions		Class 2M2
	Storage		As per IEC 721-3-1
	Climatic conditions		Class 1K3
	Temperature		-25...60 °C
	Humidity		<95% r.h.
	 conformity	EMC directive	2004/108/EC
	Low-voltage directive	2006/95/EC	
 C-tick conformity to EMC emission standard		AS/NSZ 4251.1:1999	
	Reduction of hazardous substances	2002/95/EC	
Product standards			
Automatic electrical controls for household and similar use		EN 60730-1	
Special requirements for temperature-dependent controls		EN 60730-2-9	
Electronic control type		2.B (microdisconnection on operation)	
Electromagnetic compatibility			
Emissions (residential)		IEC/EN 61000-6-3	
Immunity (industrial and residential)		IEC/EN 61000-6-2	
Protective class		II as per EN 60730	
Pollution class		Normal	
Degree of protection of housing		IP 30 to EN 60529	
Connection terminals		Solid wires or prepared stranded wires 1 x 0.4...1.5 mm ²	
Housing front color		RAL 9003 white	
Weight	RDF3..., RDF4...	0.220 kg	
	RDF600...	0.150 kg	
General			

Connection terminals

RDF300.../RDF400...
RDF600...

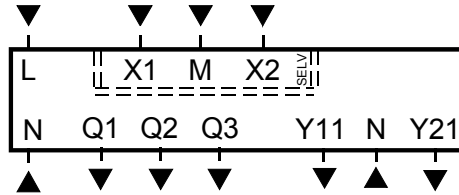

L, N Operating voltage AC 230 V
Q1 Control output "Fan speed 1 AC 230 V"
Q2 Control output "Fan speed 2 AC 230 V"
Q3 Control output "Fan speed 3 AC 230 V"
Y11, Y21 Control output "Valve" AC 230 V (N.O., for normally closed valves), output for compressor or output for electric heater
X1, X2 Multifunctional input for temperature sensor (e.g. QAH11.1) or potential-free switch
M Measuring neutral for sensor and switch

RDF340...

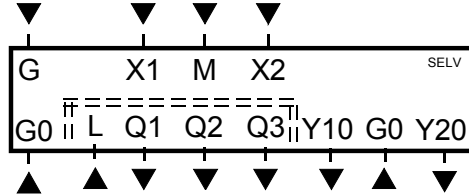

G, G0 Operating voltage thermostat AC 24 V
L Operating voltage for fan AC 230 V
Q1 Control output "Fan speed 1 AC 230 V"
Q2 Control output "Fan speed 2 AC 230 V"
Q3 Control output "Fan speed 3 AC 230 V"
Y10, Y20 Control output for DC 0...10 V actuator
X1, X2 Multifunctional input for temperature sensor (e.g. QAH11.1) or switch
M Measuring neutral for sensor and switch

Connection diagrams

RDF300..., RDF400..., RDF600...

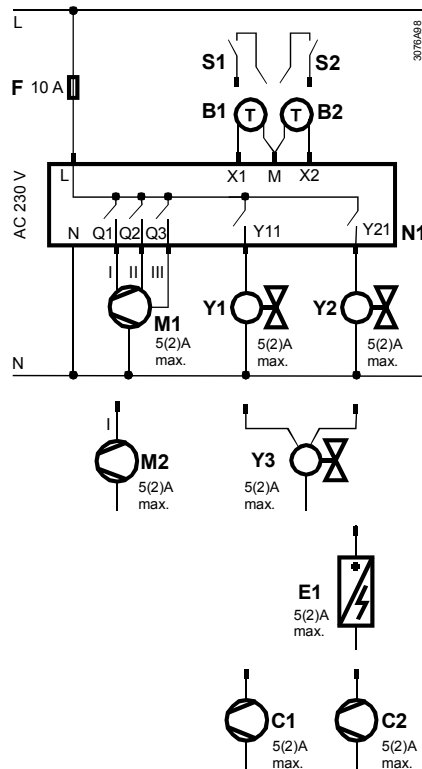

N1 Room thermostat RDF300... / RDF400... / RDF600
M1 3-speed fan
M2 1-speed fan
Y1...Y3 Valve actuator
E1 Electric heater
S1, S2 Switch (keycard, window contact, etc.)
B1, B2 Temperature sensor (return air temperature, external room temperature, changeover sensor, etc.)
C1, C2 Compressor

RDF340...

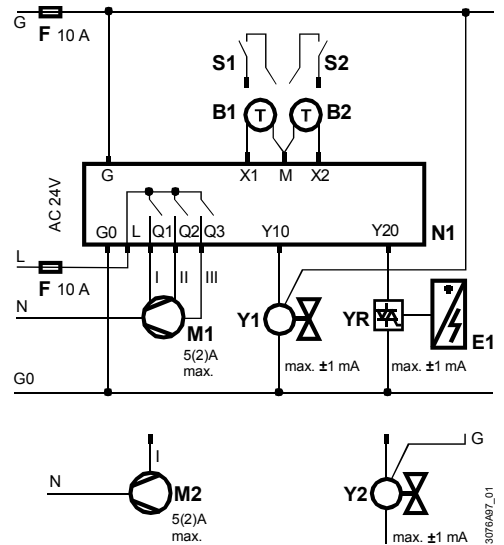

N1 Room thermostat RDF340...
M1 3-speed fan
M2 1-speed fan
Y1, Y2 Valve actuator
YR DC 0...10 signal converter/current valve
E1 Electric heater
S1, S2 Switch (keycard, window contact, etc.)
B1, B2 Temperature sensor (return air temperature, external room temperature, changeover sensor, etc.)

Dimensions

Dimensions in mm

RDF3... RDF400...

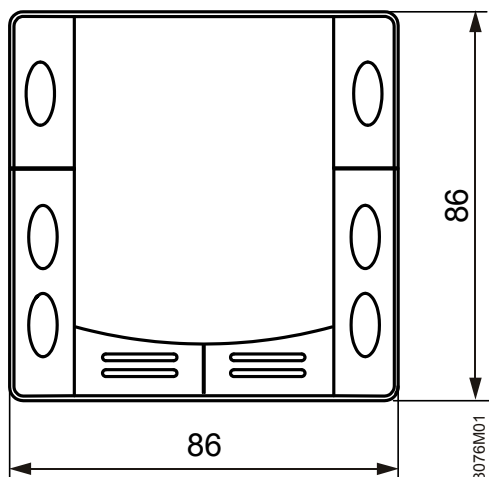

RDF600...

