

## Heating controllers

## RVP36..

for 2 heating circuits and d.h.w.

---

**Multifunctional heating controllers with LPB communication capability for residential and nonresidential buildings. Suited for the control of 2 heating circuits and d.h.w. heating. 6 programmed plant types. Operating voltage AC 230 V.**

### Use

---

- Types of plants:
  - Heating zones
  - Heating zones and d.h.w. heating
  - Heating zones and d.h.w. heating with own heat generation
  - Interconnected plants consisting of several heating zones each with 2 autonomous heating circuits and integrated d.h.w. heating
- Types of buildings:
  - Residential and nonresidential buildings
- Types of heating systems:
  - All types of standard heating systems, such as radiator, convector, floor and ceiling heating systems, plus radiant panels
- Types of d.h.w. heating systems:
  - With storage tank
  - With electric immersion heater and solar collector

## Functions

---

### Heating circuit control

- Weather-compensated flow temperature control
- Weather-compensated flow temperature control with room influence
- Demand-based control of the boiler temperature

### D.h.w. control

- D.h.w. heating with coil type storage tanks and charging pump
- D.h.w. heating with electric immersion heater and solar collector

### Other functions

- Optimized heating up and setback
- Automatic heating limit (automatic ECO function)
- Frost protection (building, plant, and d.h.w.)
- Year clock with automatic summer- / wintertime changeover
- Autonomous scheduler programs for space heating and d.h.w.
- Limitation of maximum rate of flow temperature increase
- Communication via LPB (Local Process Bus, only RVP360)
- Pump kick
- Relay and sensor test
- Remote control via room units

## Type summary

---

<i>Description</i>	<i>Instructions in ...</i>	<i>Product no.</i>	<i>Stock no.</i>
<b>Heating controller</b> for 2 heating circuits and d.h.w., communicating	German, English, French, Italian, Dutch, Spanish, Greek, and Russian	<b>RVP360</b>	S55370-C139
<b>Heating controller</b> for 2 heating circuits and d.h.w., noncommunicating	German, English, French, Italian, Dutch, Spanish, Greek, and Russian	<b>RVP361</b>	S55370-C140

## Ordering

---

When ordering, please give product no., for example **RVP360**.  
The controllers are supplied complete with Operating and Installation Instructions.

### Note

Sensors, room units, actuators and valves must be ordered separately.

## Equipment combinations

---

### Suitable sensors and room units

- Flow, return, and d.h.w. temperature:  
All types of sensors using a sensing element LG-Ni1000, for example:
  - Strapon sensor QAD22
  - Immersion sensors QAE212... and QAP21.3
  - Collector sensor QAP21.2 (solar)
- Room temperature:
  - Room unit QAW50 (PPS)
  - Room units QAW50.03 and QAW70 (PPS, both addressable)
  - Room sensor QAA24 (sensing element LG-Ni1000)If a room unit or room sensor is used in both heating circuits, one of them must be addressable. This means:
  - The first room unit can be a QAW50, QAW50.03 or QAW70
  - The second room unit must be a QAW50.03 or QAW70
- Outside temperature:
  - Outside sensor QAC22 (sensing element LG-Ni1000)
  - Outside sensor QAC32 (sensing element NTC 575)

Note The controllers identify automatically the type of sensor used.

### Suitable actuators

The following types of actuators from Siemens can be used:

- 3-position actuators with a running time of 30...873 s
- 2-position actuators
- Operating voltage AC 24...230 V

For more detailed information about actuators and valves, refer to the respective Data Sheets.

## Product documentation

---

<i>Type of document</i>	<i>Document no.</i>	<i>Stock no.</i>
Operating Instructions Language set: de, en, fr, it, nl, es, el, ru	B2546	74 319 0818 0
Installation Instructions Language set: de, en, fr, it, nl, es, el, ru	G2546	74 319 0817 0
Basic Documentation	P2546	STEP Web Client
CE Declaration of Conformity	T2545	STEP Web Client
Environmental Declaration	E2545	STEP Web Client

## Technical design

---

### Mode of operation

The RVP36... make possible the configuration of 6 plant types as combinations of heat generation and different types of heating circuits and d.h.w. heating.

When commissioning a plant, the respective plant type is to be entered. The required functions, settings and displays are then automatically assigned, and parameters that are not required will be hidden.

Note Optional functions necessitate extra configurations.

**Plant types 4 - x**

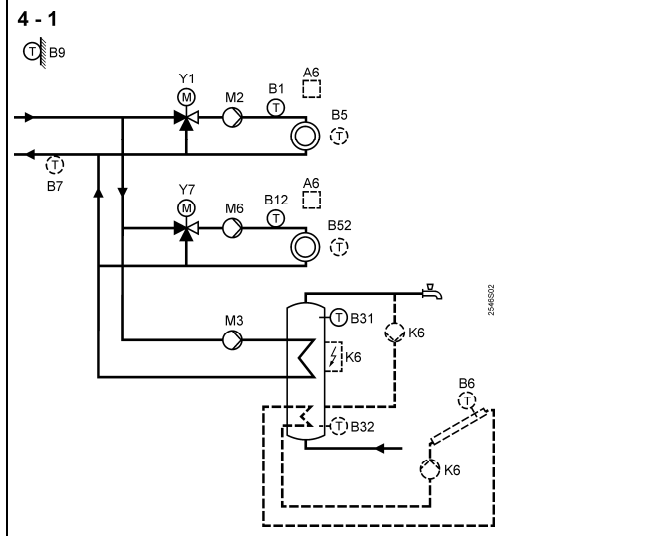
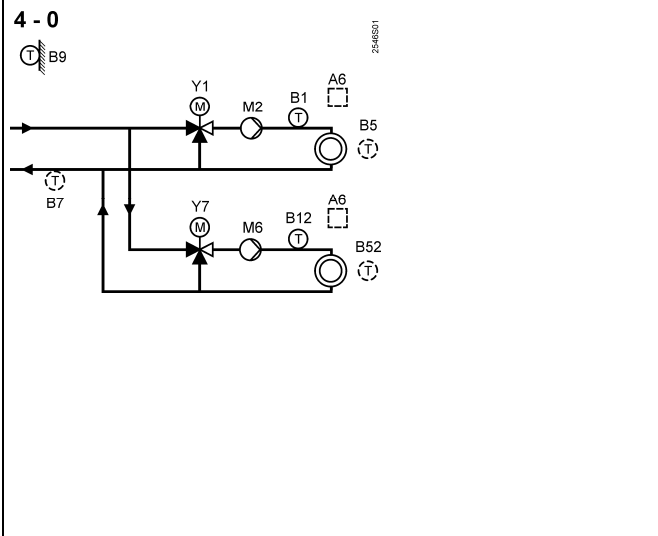



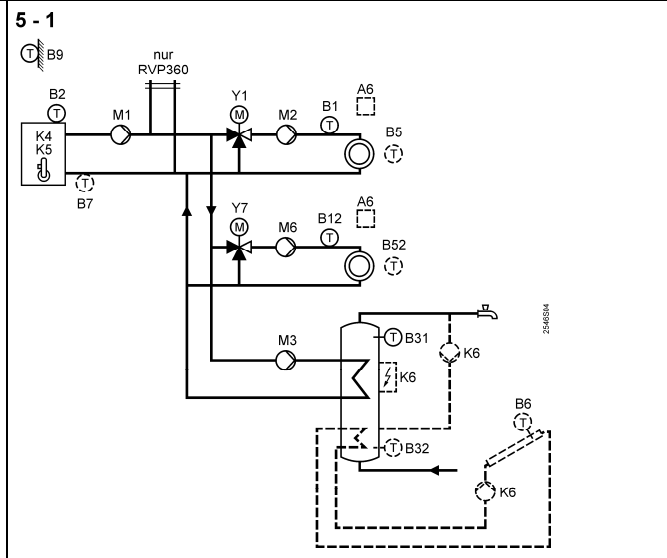
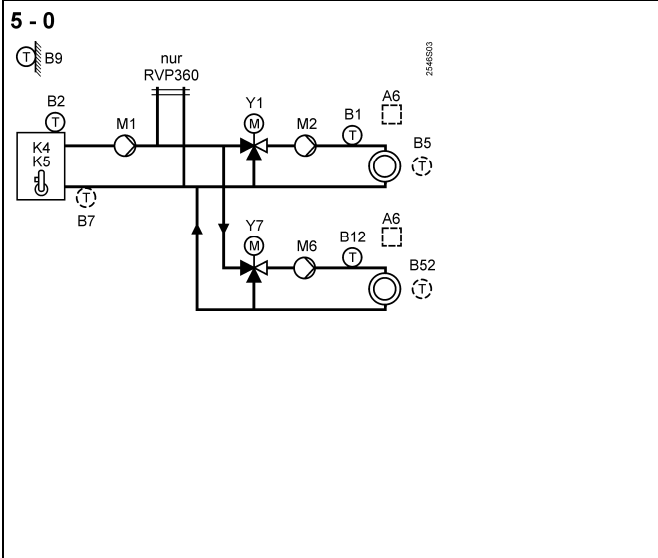

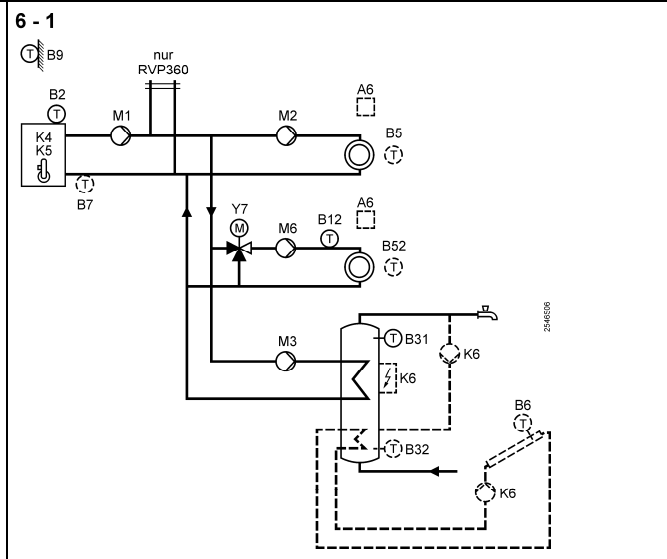
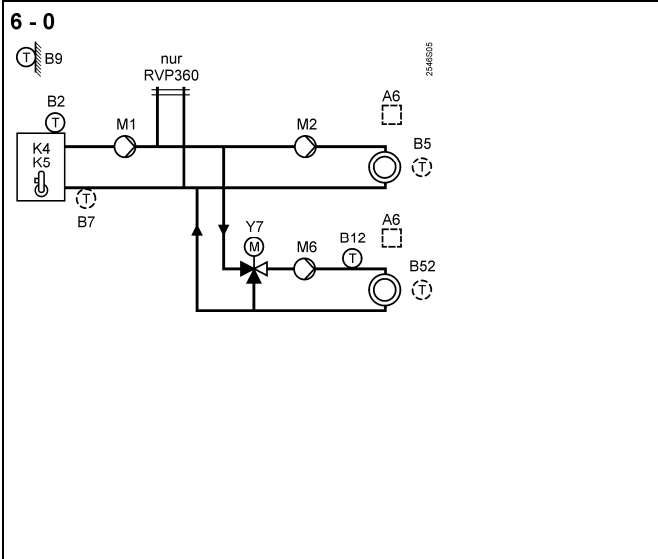

**Plant types 5 - x**



**Plant types 6 - x**



## Operating modes

-  **Automatic operation**  
Automatic heating operation with changeover between normal and reduced operation according to scheduler program, automatic ECO function and room unit active
-  **Reduced operation**  
Continuous heating to reduced room temperature, automatic ECO function active
-  **Normal operation**  
Continuous heating to normal room temperature
-  **Protection mode**  
Heating operation off, frost protection ensured
-  **Automatic d.h.w. heating**
-  **Manual control**  
No automatic control, pumps in operation

## Notes

- Frost protection is ensured in all operating modes
- The heating circuit's operating mode has no impact on d.h.w. heating

## Heating circuit control

The RVP36.. provides control of 2 mixing heating circuits or of 1 pump heating circuit and 1 mixing heating circuit.

## Compensating variables

With weather-compensated control, the composite outside temperature is used as the compensating variable. It is generated from the current and the attenuated outside temperature (calculated by the controller). The building time constant is adjustable.

## Setpoints

Adjustable are the room temperature setpoints for NORMAL and REDUCED heating and for holiday plus protection mode.  
Using the setting knobs on the controller front, the NORMAL room temperature setpoint for heating circuit 1 and heating circuit 2 can be readjusted by  $\pm 4.5$  °C.

## Generation of flow temperature setpoint

- The assigned flow temperature setpoint is generated as follows:
- Weather-compensated control: The setpoint is continuously shifted by the outside temperature. The heating curve assigns the flow temperature to the current outside temperature
  - Weather-compensated control with room influence: The setpoint is shifted by the outside temperature and the deviation of current room temperature and room temperature setpoint
  - The maximum rate of flow temperature increase can be set

## Controlled variable

The controlled variable of each heating circuit is the flow temperature. It is controlled via the heating circuit's mixing valve or the boiler temperature.

## Heating curve

With weather-compensated control, the heating curve assigns the flow temperature to the outside temperature. Its basic setting is made on 2 operating lines.

## Optimization

The control is optimized; switching on, heating up and switching off are controlled in such a way that the required room temperature is always ensured during occupancy times.  
At the end of occupancy, the heating (circulating pump) is switched off until the room temperature has dropped to the setpoint for non-occupancy (quick setback, can be deactivated).  
Maximum limit values can be set for the heating up time and for early shutdown.  
The optimization functions can be deactivated.

Automatic ECO function	The automatic ECO function controls the heating system depending on demand; it is deactivated when permitted by the progression of the outside temperature. The function gives consideration to the current, the attenuated and the composite outside temperature plus 2 adjustable heating limits; 1 for normal heating and 1 for reduced heating. The automatic ECO function requires an outside sensor. It can be deactivated, if required.
Max. and min. limitation of flow temperature	For the flow temperature, maximum and minimum limitation and a maximum rate of setpoint increase (heating up brake) can be set. Active limitations are displayed.
Frost protection for the building	Frost protection for the building ensures an adjustable minimum room temperature. This function cannot be deactivated.
Frost protection for the plant	Frost protection for the plant activates the heating circuit pump to protect the heating plant against freeze-ups. Outside temperature and flow temperature setpoint for frost protection are adjustable. The function can be deactivated, if required.
<b>Heat generation</b>	Boiler control operates as demand-based 2-position control. The boiler temperature is controlled by switching a 1- or 2-stage burner (direct burner control). 2-stage operation is enabled when the release integral is reached; it is disabled when the reset integral is reached. Both integrals are adjustable. When there is no demand for heat, the boiler is either shut down or controlled to the minimum limit value (selectable). Minimum and maximum limitation of the boiler temperature are adjustable.
Minimum limitation of return temperature	Minimum limitation protects the boiler against flue gas corrosion. Active limitations are displayed.
<b>D.h.w. heating</b>	The RVP36.. makes possible d.h.w. heating with a coil type storage tank, storage tank charging pump and 2 sensors.
Adjustments	Adjustable are the normal and the reduced temperature setpoint, boost, switching differential, overrun time of charging pump, and maximum time of d.h.w. charging.
Releases	Release of d.h.w. charging and of the circulating pump can be selected: <ul style="list-style-type: none"> <li>• Always (24 hours a day)</li> <li>• According to the scheduler program of d.h.w. heating</li> <li>• According to the controller's heating circuit scheduler program (d.h.w. charging with forward shift of first daily release)</li> <li>• According to the heating circuit scheduler programs of the controllers on the data bus</li> </ul>
Forced charging	D.h.w. charging takes place daily, always with the first release (or at midnight with the 24-hour program). It is also effected when the actual value lies within the switching differential.
Manual charging	<ul style="list-style-type: none"> <li>• Independent of scheduler program and temperature conditions</li> <li>• During protection mode for the heating circuits</li> </ul>

Priority	<p>The heating circuits' behavior during d.h.w. charging is selectable:</p> <ul style="list-style-type: none"> <li>• Absolute: Heating circuit pumps OFF or heating circuit mixing valve CLOSED and pumps ON</li> <li>• Shifting: Heating circuit pumps remain ON as long as heating energy is available. Control to d.h.w. setpoint or maximum setpoint</li> <li>• Parallel: No priority; heating circuits remain ON. Control to d.h.w. setpoint or maximum setpoint</li> </ul>
Frost protection for d.h.w.	A minimum d.h.w. temperature of 5 °C is always maintained.
Legionella function	Periodic heating up of d.h.w. ensures protection against legionella viruses.
Circulating pump, electric immersion heater, and solar collector	For the plant types with d.h.w. storage tank, a multifunctional relay for the circulating pump, d.h.w. heating with electric immersion heater and solar collector can be parameterized.
<b>Other functions</b>	
Scheduler programs	<p>For automatic heating operation, the RVP36.. features a 7-day program with 3 adjustable heating phases per day. Another 7-day program is available for the release of d.h.w.charging.</p> <p>Using the year clock with automatic summer- / wintertime changeover, a holiday period for each heating circuit can be programmed. During the holiday period, heating circuit control operates in protection mode.</p>
Remote control via room unit	<ul style="list-style-type: none"> <li>• Room units QAW50 and QAW50.03: Changeover of operating mode, readjustment of room temperature setpoint</li> <li>• Room unit QAW70: Overriding setpoints, the heating program and the holiday program</li> <li>• It is possible to use 1 room unit per heating circuit</li> </ul>
Pulse lock with actuators	To protect the relay contacts, the total duration of the OPEN / CLOSE pulses delivered to an actuator is limited to 5 times the actuator running time.
Multifunctional relay	<p>The RVP36.. has a multifunctional relay which offers the following choices:</p> <ul style="list-style-type: none"> <li>• Alarm contact for error messages</li> <li>• ON / OFF according to heat demand</li> <li>• Control of circulating pump</li> <li>• Control of electric immersion heater</li> <li>• Control of collector pump</li> </ul>
Pump kick	To prevent pump seizing, a kick can be set for all pumps. The pump kick is made once a week and lasts 30 seconds.
Pump overrun	To prevent the accumulation of heat, a pump overrun time can be set.
Relay and sensor test	<p>To facilitate commissioning and fault tracing, the controller offers the following choices:</p> <ul style="list-style-type: none"> <li>• Relay test: The relays can be manually energized</li> <li>• Sensor test: The current sensor values can be queried</li> <li>• Display of setpoints: The current setpoints can be displayed</li> </ul>

Communication  
(only RVP360)

Via LPB, e.g. locking and forced signals, assignment of d.h.w., master-slave assignments for the time switch, outside temperature signal, heat demand to heat generation, error messages.

Manual control

The heating system can be controlled manually while d.h.w. heating remains activated. The relays are energized as follows:

- Burner ON
- Actuators dead, but can be manually controlled via the controller
- Heating circuit pumps activated
- Collector pump activated and electric immersion heater released

## Mechanical design

### Controller

The controller consists of insert and base. The controller insert contains the electronics, the power section and 11 relays. The front of the controller carries the operating elements and the backlit LCD. 2 screws are used to secure the controller insert to the base. The base accommodates the connection terminals. The Operating Instructions supplied with the controller can be inserted at the rear of the cover.

### Display and operating elements

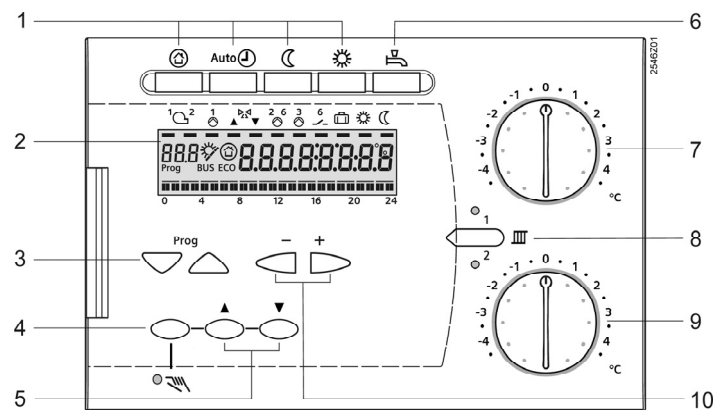

- 1 Buttons for selecting the operating mode
- 2 Display (LCD)
- 3 Buttons for selecting the operating lines
- 4 Button for manual control ON / OFF
- 5 Buttons for valve OPEN / CLOSE when manual control ON
- 6 Button for d.h.w. heating ON / OFF
- 7 Knob for readjusting the room temperature setpoint of heating circuit 1
- 8 Button for switching between the heating circuits
- 9 Knob for readjusting the room temperature setpoint of heating circuit 2
- 10 Buttons for adjusting the values

### Operation

- Operating elements:
  - Knob for readjusting the room temperature setpoint of heating circuit 1
  - Knob for readjusting the room temperature setpoint of heating circuit 2
  - Button for switching between the heating circuits
  - Button for the respective operating mode
  - Buttons for manual control and manual positioning commands
  - Button for d.h.w. heating
- The setting and changing of all other parameters, the activation of functions and the reading of actual values and operating states are based on the operating line principle. An operating line with its number is assigned to each parameter, each actual value and each function. The operating lines are selected with buttons 3, and the values are changed with buttons 10.



## Notes

---

### Engineering

#### Electrical installation

- The cables of the measuring circuits carry extra low-voltage
- The cables to the actuators, the burner and the pumps carry AC 24...230 V
- Local electrical safety regulations must be complied with
- Sensor wires should not be run parallel to mains carrying cables powering actuators, pumps, burner, etc.

#### Radiator valves

In the case of control systems using room units or room sensors, the reference room must not be equipped with thermostatic radiator valves; manual valves must be locked in their fully open position.

#### Lightning protection

- If bus cables are laid outside buildings, the controls are exposed to transients resulting from lightning strokes and must be appropriately protected
- Every bus cable and the devices to be protected demand matching protective equipment
- The protection function is ensured only if the installation is made correctly
- For notes on installation in compliance with EMC requirements, refer to Data Sheet N2034

### Installation

#### Mounting choices

- Wall mounting (on a wall, in the control panel, etc.)
- Mounting on a top hat rail
- Flush mounting (cutout in control panel door, etc.)

#### Mounting locations

Suitable mounting locations are control panels, control desks, compact stations or the heating room. Not permitted are damp or wet spaces.

#### Electrical connections

All connection terminals for protective extra low-voltage (sensors and room units) are located on the upper terminal block, those for mains voltage (actuators, burner, and pumps) on the lower terminal block.

### Commissioning

- The plant type must be selected
- The settings can be locked on the software side
- The controllers are supplied complete with Installation and Commissioning Instructions
- "Address 2" must be set on the room unit for heating circuit 2

### Disposal

---



In terms of disposal, the controllers are classified as electronic scrap conforming to the European Directive 2002/96/EG (WEEE) and must not be disposed of as domestic waste. The relevant national legal regulations must be complied with and the controllers must be disposed of via the appropriate channels. Local and currently valid legislation must be observed.

### Warranty

---

**If using the RVP36.. controllers in connection with third-party devices, the correct functioning must be ensured by the user. In that case, Siemens will assume no responsibility for service and warranty.**

## Technical data

<b>Power supply</b>	Operating voltage	AC 230 V (+10 / -15%)	
	Rated voltage	AC 230 V	
	Frequency	50 Hz	
	Power consumption (excl. external loads)	Max. 8 VA	
	Fuse protection for supply line	Fuse slow:	max. 10 A
		Automatic cutout LS:	max. 13 A
Response characteristic of LS:		B, C, D, as per EN 60898	
<hr/>			
<b>Inputs</b>			
Sensor inputs (B...)	Sensing elements	Refer to "Equipment combinations"	
<hr/>			
<b>Outputs</b>			
Relay outputs	Voltage	AC 24...230 V	
	Current K4, K5	AC 0.02...2(2) A	
	Current Q1, Q3, Y1, Y2, Q2, Q6, K6, Y7, Y8	AC 0.02...1(1) A	
	Rated current ignition transformer	Max. 1 A, max. 30 s	
	Starting current ignition transformer	Max. 10 A, max. 10 ms	
<hr/>			
<b>Interfaces</b>			
LPB	Connection	2-wire (not interchangeable)	
	Bus loading number E	RVP360: 10	
<hr/>			
PPS	Connection (room unit or sensor)	2-wire (interchangeable)	
<hr/>			
<b>Permissible cable lengths</b>	For all sensors		
	Copper cable 0.6 mm dia.	20 m	
	Copper cable 1.0 mm <sup>2</sup>	80 m	
	Copper cable 1.5 mm <sup>2</sup>	120 m	
	For room units (PPS)		
	Copper cable 0.25 mm <sup>2</sup>	25 m	
Copper cable from 0.5 mm <sup>2</sup>	50 m		
<hr/>			
<b>Electrical connections</b>	Screw terminals	For cross-sectional areas up to 2.5 mm <sup>2</sup>	
<hr/>			
<b>Backup</b>	Time switch	12 hours	
<hr/>			
<b>Standards and directives</b>	CE conformity as per		
	EMC directive	2004/108/EG	
	immunity and emissions	EN 60730-1 (suited for use in residential and industrial environments)	
	Low-voltage directive	2006/95/EG	
	Electrical safety	EN 60730-1 / EN 60730-2-9	
CE C-tick conformity	AS/NZS 61000-6-3		
<hr/>			

Classifications as per EN 60730	Software class Mode of operation	A 1B (automatic)		
Protective data	Safety class	II as per EN 60730 (if correctly installed)		
	Degree of protection of housing	IP40 as per EN 60529 (if correctly installed)		
	Degree of pollution	2 as per EN 60730		
Environmental compatibility	The Environmental Declaration contains data on environmental-compatible product design and assessment (RoHS compliance, compositions, packaging, environmental benefits and disposal)	ISO 14001 (environment) ISO 9001 (quality) SN 36350 (environment-compatible products) RL 2002/95/EG (RoHS)		
<b>Dimensions</b>	Refer to "Dimensions"			
<b>Weight</b>	Controller (net)	0.66 kg		
<b>Housing colors</b>	Housing	Light-grey RAL 7035		
	Base	Pigeon-blue RAL 5014		
<b>Permissible ambient conditions</b>		<i>Operation</i> <i>EN 60721-3-3</i>	<i>Transport</i> <i>EN 60721-3-2</i>	<i>Storage</i> <i>EN 60721-3-1</i>
	Climatic conditions	Class 3K5	Class 2K3	Class 1K3
	Temperature	0...50 °C	-25...70 °C	-20...65 °C
	Humidity	<95% r.h. (noncondensing)	<95% r.h.	<95% r.h. (noncondensing)
	Mechanical conditions	Class 3M2	Class 2M2	Class 1M2
	Altitude of operation	Max. 3000 m above sea level		

## Connection diagrams

### Low-voltage side

\* LPB only RVP360

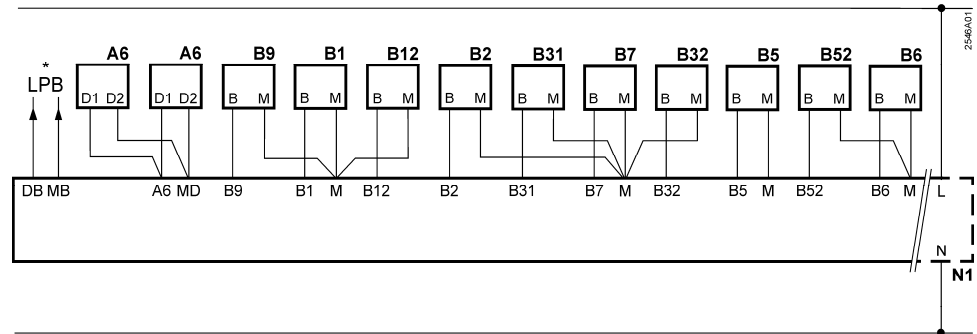

### Mains voltage side

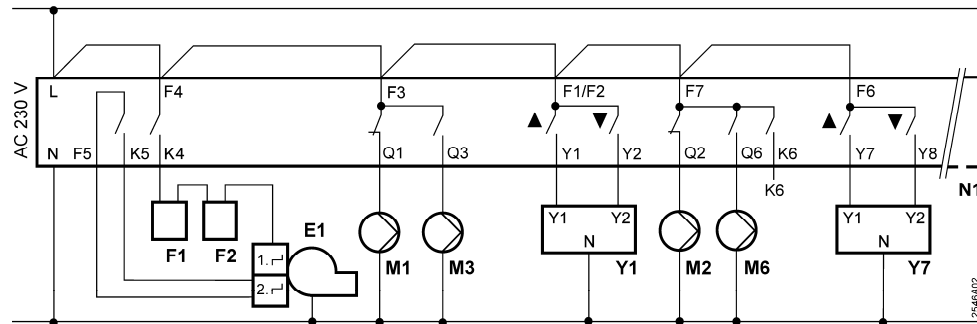

- A6 Room unit
- B1 Flow sensor heating circuit 1
- B12 Flow sensor heating circuit 2
- B2 Boiler sensor
- B31 D.h.w. storage tank sensor / thermostat
- B32 D.h.w. storage tank sensor / thermostat
- B5 Room sensor heating circuit 1
- B52 Room sensor heating circuit 2
- B6 Collector sensor
- B7 Return sensor
- B9 Outside sensor
- E1 2-stage burner
- F1 Thermal reset limit thermostat
- F2 Safety limit thermostat
- K6 Multifunctional output
- LPB Data bus (only RVP360)
- M1 Circulating pump
- M2 Heating circuit pump heating circuit 1
- M3 Storage tank charging pump
- M6 Heating circuit pump heating circuit 2
- N1 Controller RVP36..
- Y1 Actuator heating circuit 1
- Y7 Actuator heating circuit 2

# Dimensions

2546M01

