

Flow switch

QVE1900

for liquids for piping DN 32...200

Use

In HVAC plants to monitor the flow of fluids in hydraulic systems, especially in refrigeration, heat pump and heating plants, e.g. for use with condensers, boilers, heat exchangers, etc.

Ordering

When ordering, please provide the name and product number:
flow switch **QVE1900**

Mechanical design

The unit comprises a base with attached screw-in body R1 (refer to "Dimensions") and cover.

The base houses the microswitch, transfer lever with adjusting screw (for switch-on/switch-off point), a paddle holder and an opening for the cable entry. Four paddles of various lengths and attaching screws for mounting the paddles are enclosed.

The cover is secured to the base with two screws.

Setting element and connection terminals

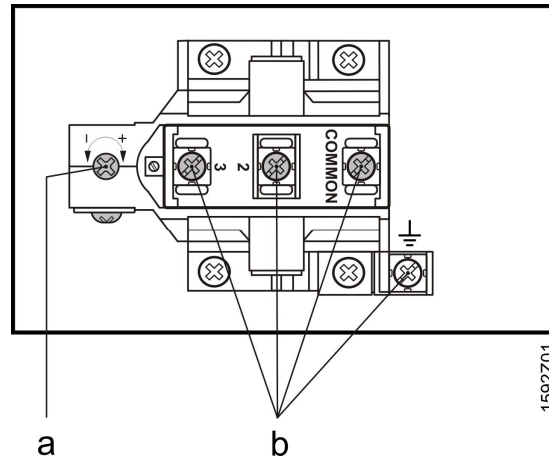

Legend:

- a Adjusting screw for switch-on/off values
- b Connection terminals

The unit is supplied with the switch-on/off values set to the minimum (See the next section "Notes")

Notes

Engineering

- On site, a T-junction R1" per EN DIN 10241 required (steel fittings with threads) and EN DIN 10242 (threaded fitting from malleable casting) required.
- All dimensions and data provided in the table of switching values are based on water at 20 °C, the use of T-junctions and **horizontal** piping.
- Before and after the mounting location of the flow switch, a smoothing path of at least 10 times or 5 times the nominal pipe diameter required.

Fitting

- Mount the enclosed cable gland and fit the T-junction R1" on-site prior to mounting the device.
- Insert vertically in the horizontal piping.
- Note the flow direction during installation (the screw-in body R1 has an arrow).
- For reasons of stability, the short paddles may not be removed with the larger pipe diameters.

Installation

- Observe all local regulations from the electrical utilities or waterworks as applicable.
- Allow for an extra loop of the connecting cable to ensure the switching value can be adjusted.

Commissioning

- A higher switch-off value can be set by turning the adjusting screw for the switch-on/off value clockwise.
- When mounting the flow switch in vertical piping, you must compensate for the weight of the paddles on the adjusting screw for the switch-on/off values (Orientation not recommended, see fitting instructions).

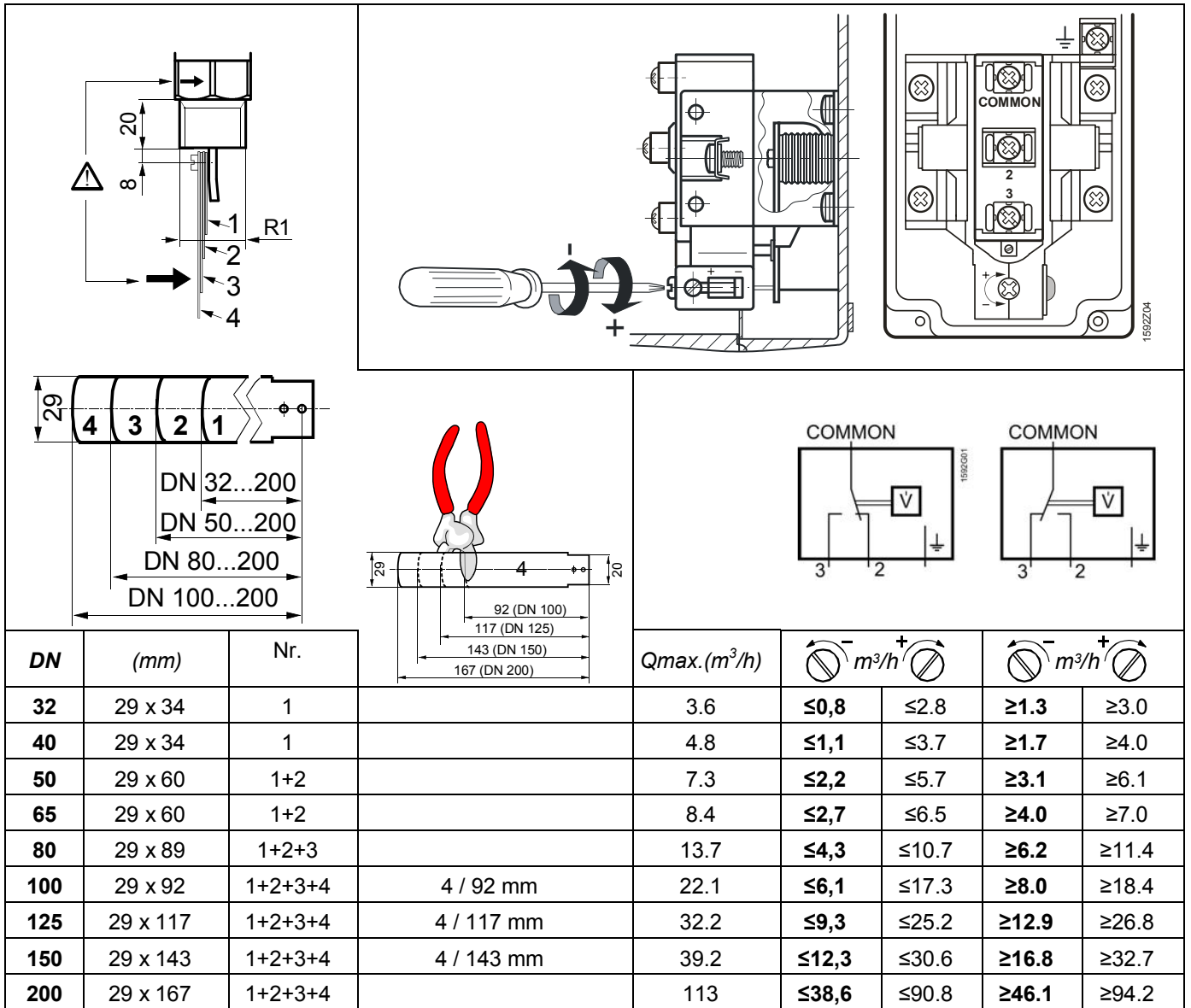

Technical data

Functional data

Field of use

Suitable media

All liquids

(not suitable for ammonia)

Piping diameter

DN 32...200

Type of switch

Microswitch

with single-pole changeover, potential free

Contact rating

AC 250 V, 15 (8) A

Adjustment of switching point

manual, supplied with minimum switch-on/off values

Setting range

Refer to switching value table

Perm. medium temperature

-20...+120 °C

(medium must be antifreeze)

Perm. operating pressure

PN 10

Protective data

Degree of protection

IP 65 per EN 60529

Safety class

I per EN 60335-1

Environmental conditions	General environmental conditions	
Standards and directives	Operation and storage	-20...+85 °C
	CE conformity to	
	Low voltage directive	2006/95/EEC
	RoHS	2011/65/EU
	Product norm	EN 60335-1
Environmental compatibility	Environmental product declaration	ISO 14001 (environment)
	CM1E1592en provides information on environmentally compatible product design and assessment (RoHS compliance, composition of substances, packaging, environmental benefit, disposal).	ISO 9001 (quality)
Materials / colors	Housing base	Bayblend T85 / color RAL 7015
	Cover	ABS / color RAL 5007
	Screw-in body R1"	Brass
	Paddle	High-grade steel (V2A)
	Flow switch, overall	Silicon free
Dimensions (weight)	Without packaging	0.570 kg

Internal diagram

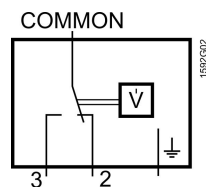

- COMMON – 3 Flow velocity \geq Switch-on value
COMMON – 2 No flow or flow velocity has fallen below the adjusted switch-off value

Dimensions

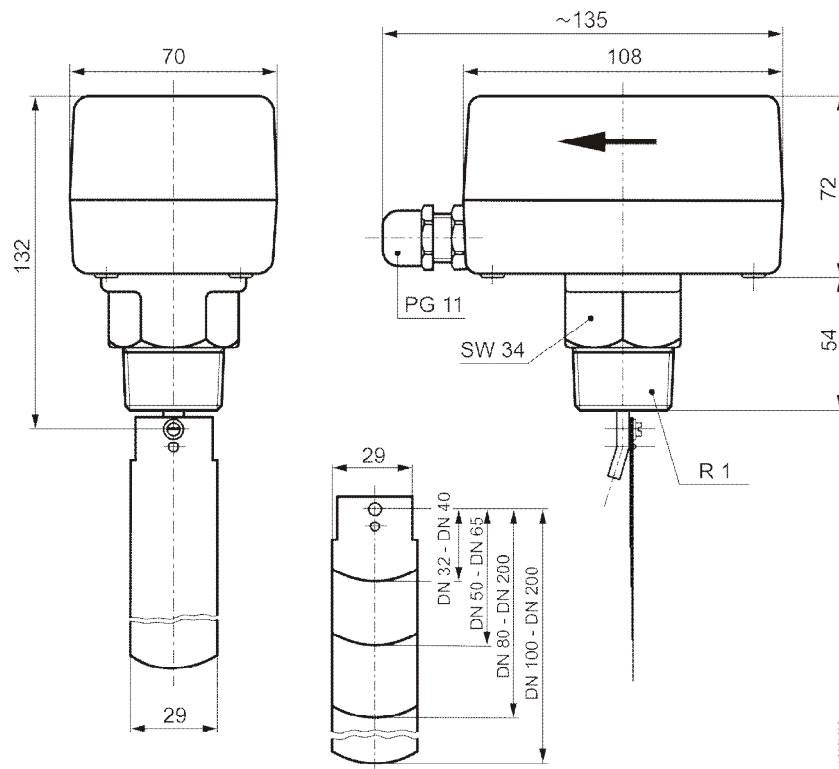

Dimensions in mm